

DOC 400

For tractors 110-150 hp (5,5 m / 6,5 m)



Hydraulic hedge mower of 5,5/6,5 m range, for tractors HP 110/150 and weight 4500/5000 kg, suitable for all working and roads, strong, compact, connected on the tractor in high position and fast on the motions.

DOC 400	A/P	s/PS/AS
A mm	5.500	6.500
B mm	5.700	6.700
C mm	4.600	5.600
D mm	3.700	4.700
E mm	4.500	5.500
F mm	550	550

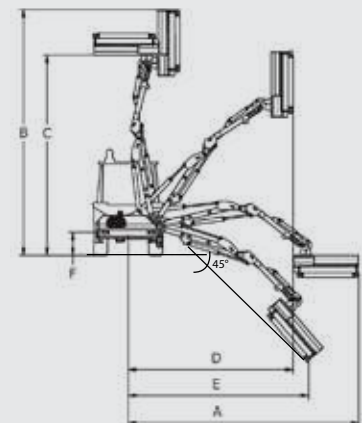

Rotor with shackle (exchangeable tools)

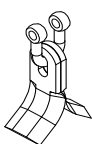

KC4
Ø max 2 cm
STANDARD EQUIPMENT

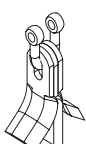

KC5
Ø max 2 cm

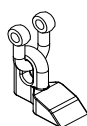

HC2
Ø max 4 cm



Rotor with bolt (exchangeable tools)



KF4
Ø max 4 cm

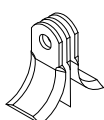

KF5
Ø max 4 cm



KF6
Ø max 3 cm



HF5
Ø max 6 cm



HF4
Ø max 6 cm

Tools n. 20 kits per rotor

Arm mower	DOC 400	DOC 400 P	DOC 400 A	DOC 400 S	DOC 400 PS	DOC 400 AS
Extension E mm	5.500	5.500	5.500	6.500	6.500	6.500
Telescopic	0	0	0	1	1	1
Weight kg	1.100	1.150	1.200	1.300	1.350	1.400
Oil tank L	260	260	260	260	260	260
Head model	30.5	30.5	30.5	30.5	30.5	30.5
Pump l/min	100+20	100+20	100+20	100+20	100+20	100+20
Hydraulic Motor HP [kW]	55 (41)	55 (41)	55 (41)	55 (41)	55 (41)	55 (41)

Tractor

Power HP [kW]	110/150 (73/110)	110/150 (73/110)	110/150 (73/110)	110/150 (73/110)	110/150 (73/110)	110/150 (73/110)
Weight kg	4.500	4.500	4.500	5.500	5.500	5.500
Width m	2,4	2,4	2,4	2,4	2,4	2,4
PTO rpm	540	540	540	540	540	540

Technical features and standard equipment

- Frame in structural steel ST 52
- Highly resistant steel DOMEX700 for 1st, 2nd arm and telescopic extension terminal with hexagonal section
- Telescopic extension terminal on guide slides on ERTALON anti-wear material
- 90° rotating column and shock resistant hydraulic safety device
- Three points hitch 2nd and 3th category
- Oil tank 260 l
- Double gear pump group 3+2 - 100+20 l/min
- Bidirectional hydraulic motor HP 55 power
- Distributor with remote controls with mm 3000 flexible cables
- Self-levelling floating system
- Feeler roller recordable on 3 positions
- Head rotating angle 200°
- Helicoidal rotor with jointed cut blade KC4
- Rotor turning at 3000 rpm
- Fixing tie-rods
- Cardan joint
- Air-oil heat exchanger with radiating mass at high thermal exchange
- Rear underrun protection with lights
- Flail head mm 1300 MODEL 30.5 TTD 130 with direct transmission

Accessories on request

- Nitrogen accumulator for 1st arm suspension
- Proportional power-assisted with joystick
- Biaxial prop. distributor with joystick SAUER DANFOSS
- Closed circuit piston Motor and Pump SAUER DANFOSS 70 hp
- Gear pump and motor PARKER - 80 hp
- Rear flail head hitch
- Belt transmission "TTC"
- Hydraulic flail head hood + additional hydraulic line (to be connected to the tractor)
- Blower (to be connected to the tractor)
- Trestle bracing + tie rods adapter
- Tie rods adapter Cat. 2 (3rd point pin 25 mm)
- Tie rods adapter Cat. 3 (3rd point pin 32 mm)

Terminal tools

In replacement of the standard mulcher

p.83



PRUNING SHEAR BAR

BTZ10 16
BTZ10 19
BTZ10 22

p.84



FOREST CUTTING DISC BAR

BD3
BD4

p.85



DITCH CLEANER

PF60
PF80