

DOC 101

For tractors 20-40 hp (3 m / 3,8 m)



Hydraulic hedge mower with side shift and mechanical release safety device for tractors HP 20/40 and weight 1000/2500 kg, with small size in phase of closing and with the possibility of several solutions of attachment: rear right, rear left, front right, front left.

| DOC 101 | 3.0 | 3.8 |
|----------------|------------|------------|
| A mm | 3.000 | 3.800 |
| B mm | 3.200 | 4.000 |
| C mm | 2.100 | 2.900 |
| D mm | 1.200 | 2.000 |
| E mm | 2.000 | 2.800 |
| F mm | 550 | 550 |

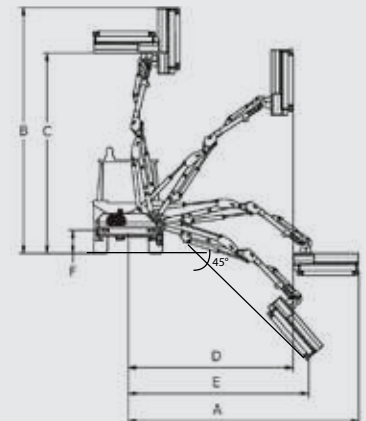

Rotor with shackle (exchangeable tools)

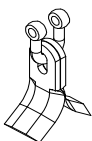

KC1
Ø max 3 cm
STANDARD EQUIPMENT

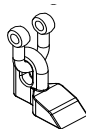

HC1
Ø max 4 cm



HF2
Ø max 5 cm



Tools n. 14 kits per rotor

| Arm mower | DOC 101 3.0 | DOC 101 3.8 |
|--------------------------------|--------------------|--------------------|
| Extension mm | 3.000 | 3.800 |
| Weight kg | 400 | 440 |
| Oil tank L | 60 | 60 |
| Head model | T3 | T3 |
| Pump l/min | 40+15 | 40+15 |
| Hydraulic Motor HP [kW] | 20 (15) | 20 (15) |

Tractor

| | | |
|-----------------------------|---------------|---------------|
| Power HP [kW] | 20/30 (15/22) | 30/40 (22/30) |
| 3-point linkage Cat. | Cat. 1 | Cat. 1 |
| Weight kg | 1.000 | 1.500 |
| Width m | 1,00 | 1,20 |
| PTO rpm | 540 | 540 |

Technical features and standard equipment

- Frame - 1st arm - 2nd arm in structural steel ST 52
- Three points hitch 1st category
- Oil tank 60 l
- Double gear pump group 2+2 - 40+15 l/min
- Bidirectional hydraulic motor HP 20 power
- Distributor with remote controls with mm 3000 flexible cables
- Self-levelling floating system
- Feeler roller recordable on 3 positions
- Head rotating angle 200°
- Helicoidal rotor with jointed cut blade KC1
- Rotor turning at 3000 rpm
- Fixing tie-rods
- Rear underrun protection with lights
- Flail head mm 900 MODEL T3 90 with direct transmission

Accessories on request

- Heat exchanger
- Electric distributor with joystick
- Electric command of the rotor
- Flail head mm 700 T3 70 - n. 10 kits of tools for rotor
- Tie rods adapter

Terminal tools

In replacement of the standard mulcher

p.82



HEDGE CUTTING BAR

BF15