

DOC 201

For tractors 50-70 hp (4,3 m/5,0 m)



Hydraulic hedge mower with side shift and mechanical release safety device for tractors HP 50/70 and weight 2000/2500 kg, suitable for working on local and trunk roads and farms.

DOC 201	4.3	5.0
A mm	4.300	5.000
B mm	4.500	5.200
C mm	3.200	4.000
D mm	2.300	3.100
E mm	3.100	3.900
F mm	550	550

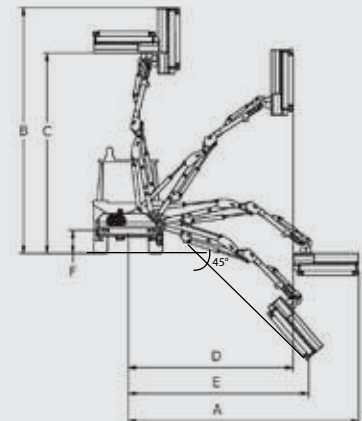

Rotor with shackle (exchangeable tools)

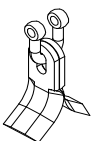

KC1
Ø max 3 cm
STANDARD EQUIPMENT

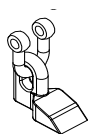

HC1
Ø max 4 cm



HF2
Ø max 5 cm



Tools n. 16 kits per rotor

Arm mower	DOC 201 4.3	DOC 201 5.0
Extension mm	4.300	5.000
Weight kg	650	685
Oil tank L	100	100
Head model	20.2	20.2
Pump l/min	60+15	60+15
Hydraulic Motor HP [kW]	35 (26)	35 (26)

Tractor

Power HP [kW]	50/70 (37/52)	50/70 (37/52)
3-point linkage Cat.	Cat. 1-2	Cat. 1-2
Weight kg	2.000	2.500
Width m	1,80	2
PTO rpm	540	540

Technical features and standard equipment

- Frame - 1st arm - 2nd arm in structural steel ST 52
- Three points hitch 2nd category
- Oil tank 100 l
- Double gear pump group 3+2 - 60+15 l/min
- Bidirectional hydraulic motor HP 42 power
- Distributor with remote controls with mm 3000 flexible cables
- Self-levelling floating system
- Feeler roller recordable on 3 positions
- Head rotating angle 200°
- Helicoidal rotor with jointed cut blade KC1
- Rotor turning at 3000 rpm
- Fixing tie-rods
- Cardan joint
- Rear underrun protection with lights
- Flail head mm 1050 MODEL 20.2 TTD 105 with direct transmission

Accessories on request

- Heat exchanger
- Electric distributor with joystick
- Electric command of the rotor
- Proportional power-assisted with joystick
- Tie rods adapter Cat. 2

Terminal tools

In replacement of the standard mulcher

p.76



MODEL
T3 90
T3 70

p.82



HEDGE CUTTING BAR
BF15

p.83



PRUNING SHEAR BAR
BTZ5 15
BTZ5 18
BTZ10 16

p.84



FOREST CUTTING DISC BAR
BD2

p.85



DITCH CLEANER
PF40